



Electric Heat Booster in Low Temperature District Heating

Hanmin Cai
Shi You
Henrik W. Binder

COPENHAGEN, 12–13 SEPTEMBER 2017

Overview

- Background
- System description
- Lab facility
- Water tank modelling
- Network service
- Potential new business



Background



- Increased penetration of renewable energy resources with intermittent power output
- Energy storage capacity needs to be found in other energy sectors
- Integrated energy system is one solution
- Nordhavn as a test bed for integrated energy system research

Nordhavn project



System view

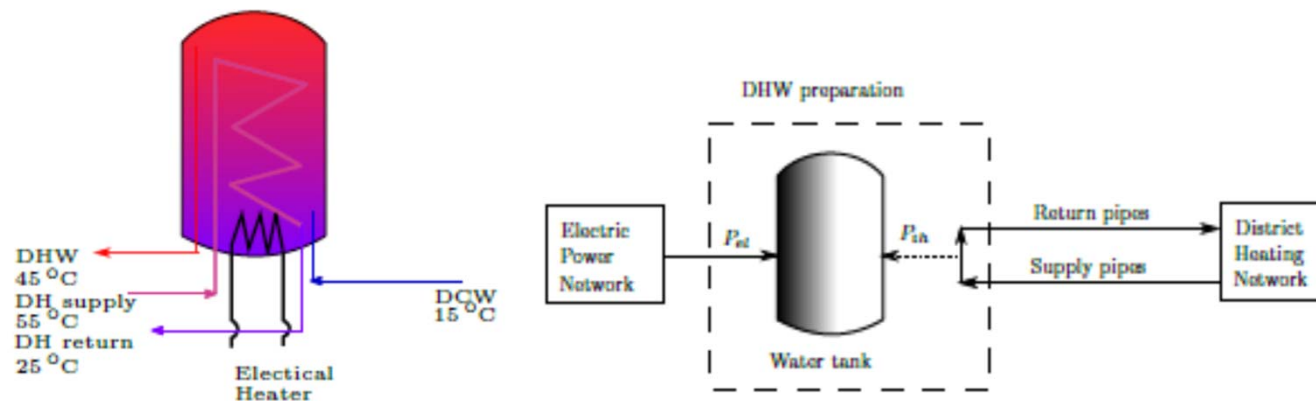
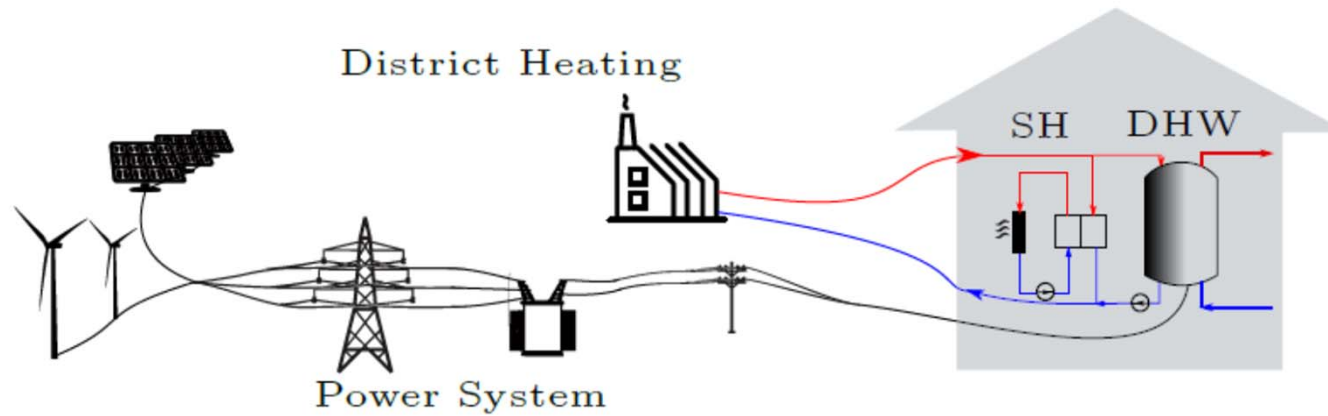

- Boost temperature up to kill legionella
- Heated by both electric and district heating
- Electric heating may have a different role in future energy system

SYSLAB

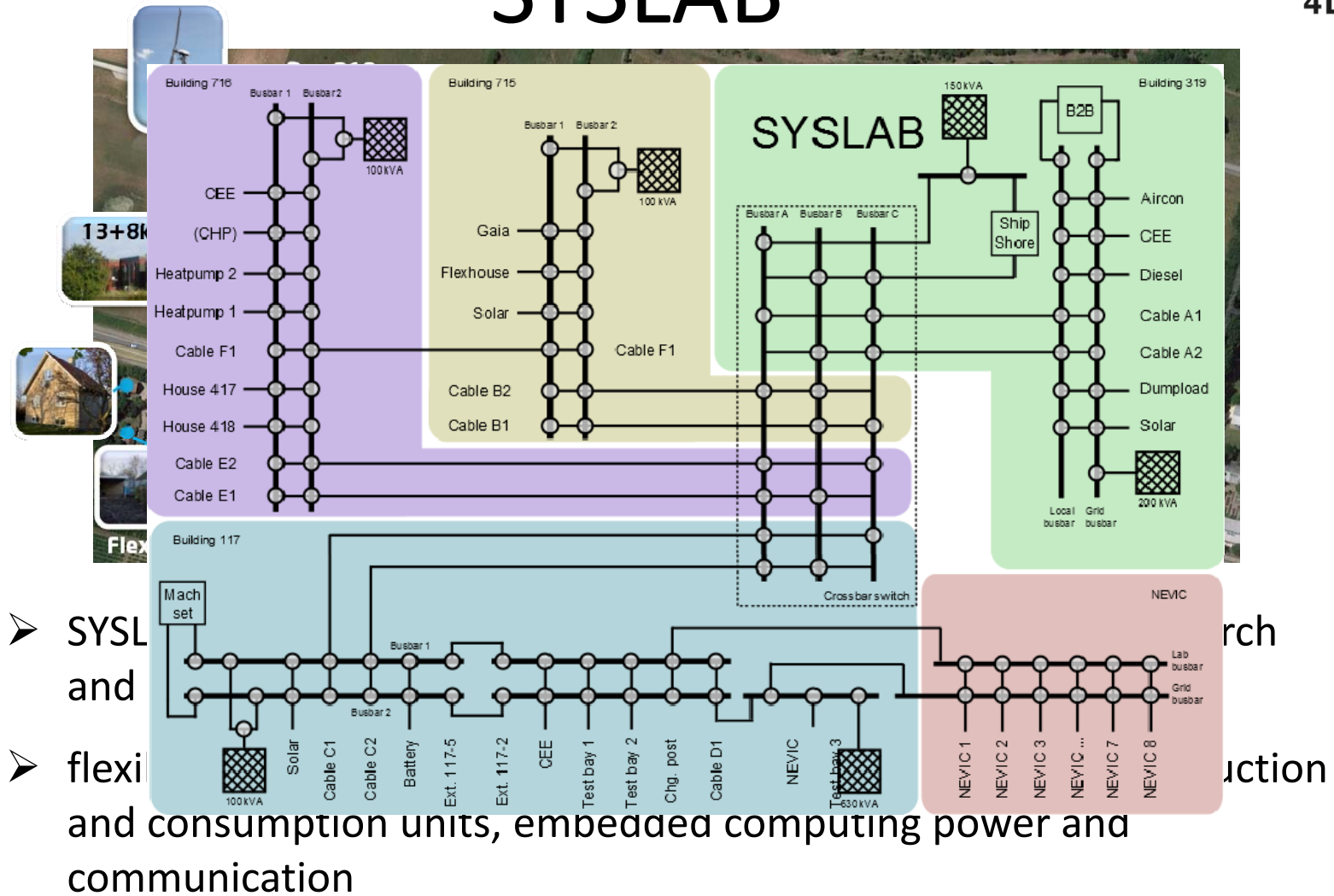

Lab facility

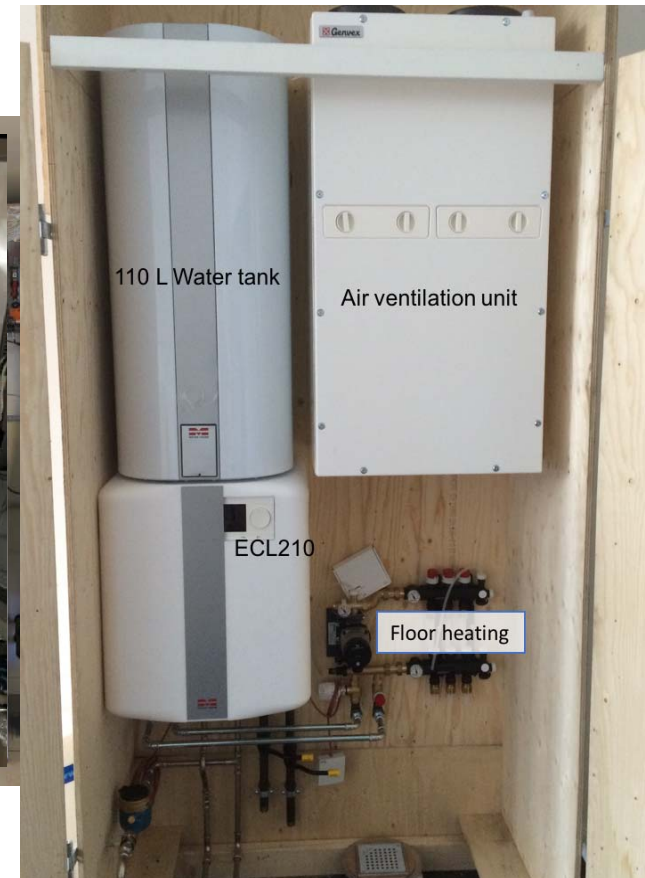
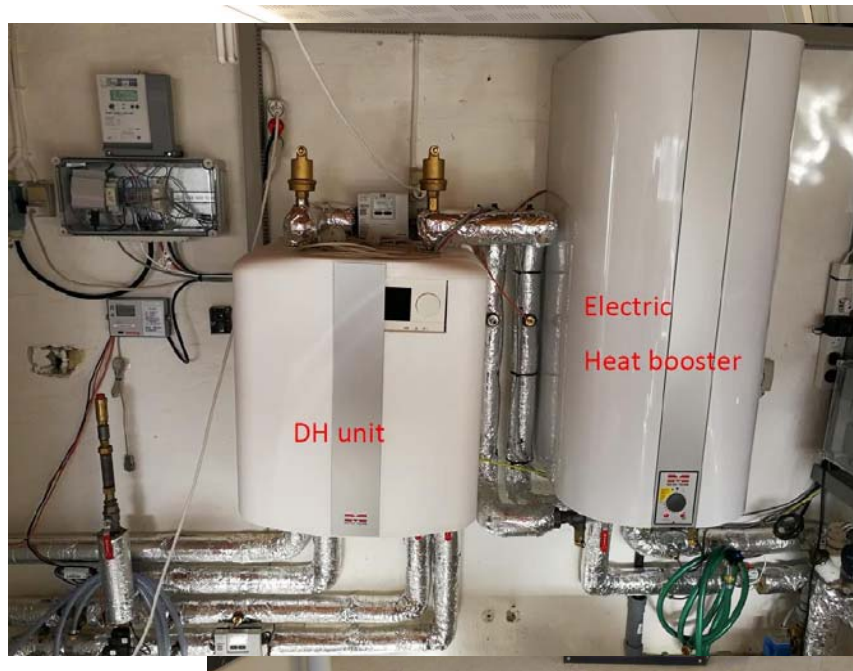

24 apartments participate in experiment

Water tank model - Comsol

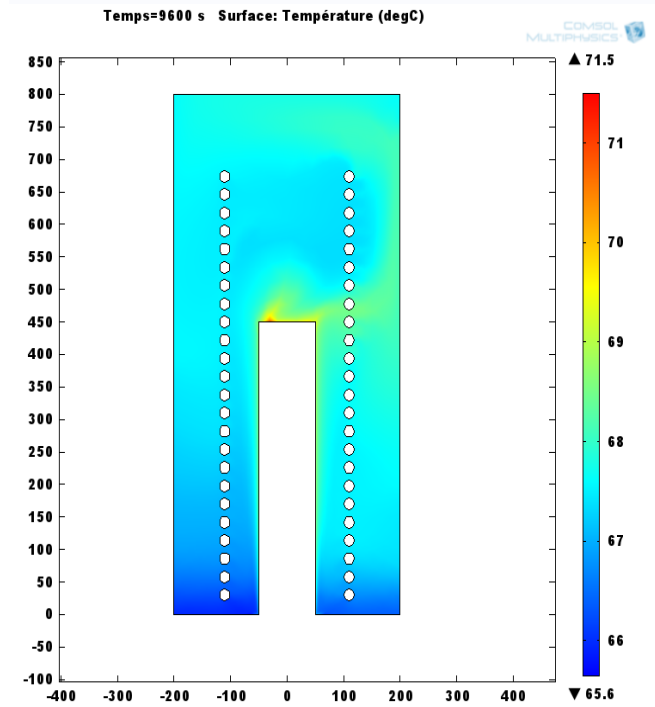

Using electric heating

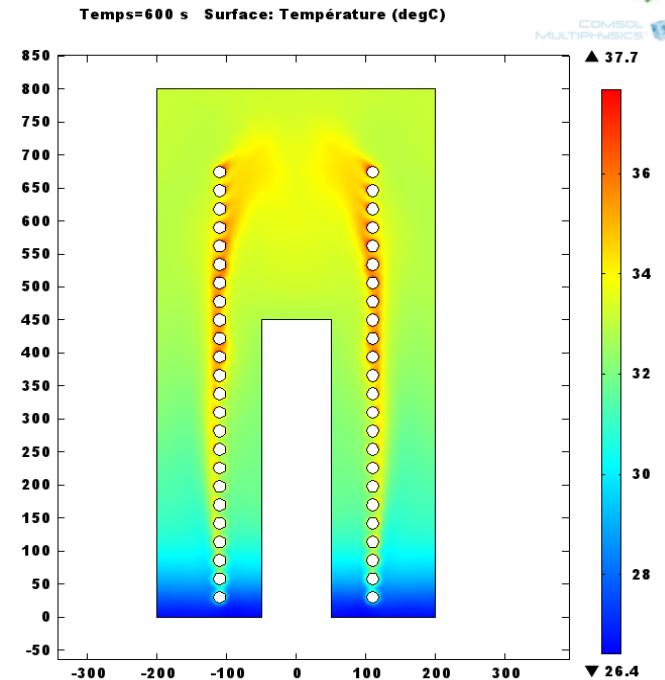

Using district heating

- Different dynamics using electric and district heating
- Simulate dynamics inside tank when only limited number of sensors available
- However, model is too complicated from the perspective of control

Water tank model - simplified

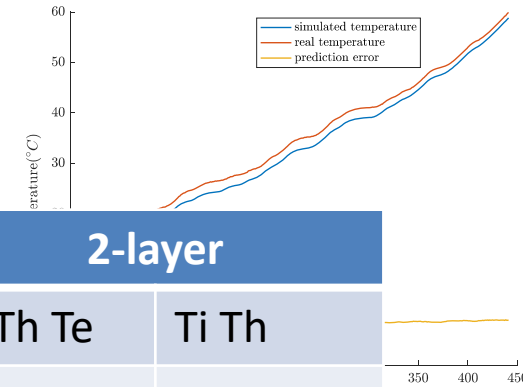
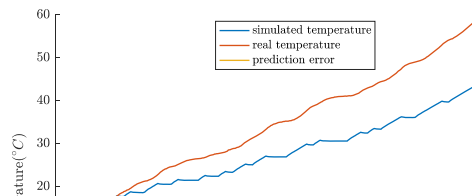
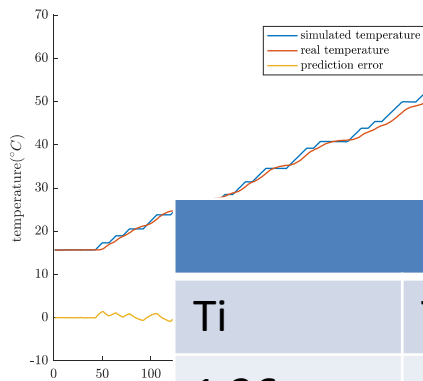
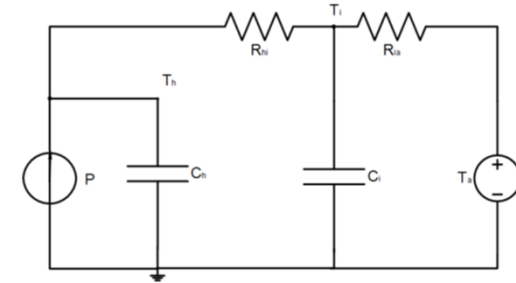
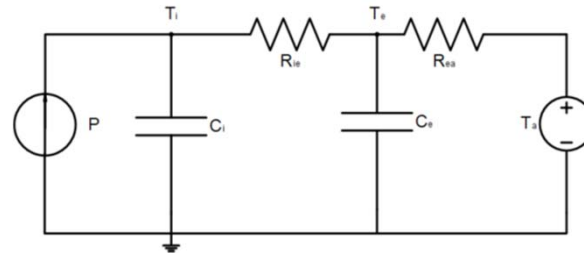
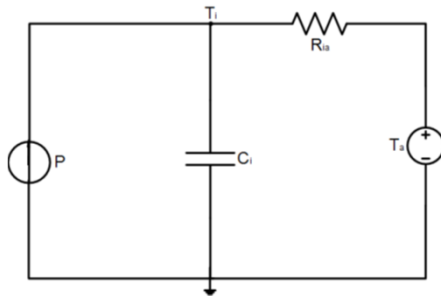

1-layer				2-layer	
Ti	Ti Te	Ti Th	Ti Th Te	Ti Th Te	Ti Th
1.36	8.29	1.58	0.92	1.77	1.11

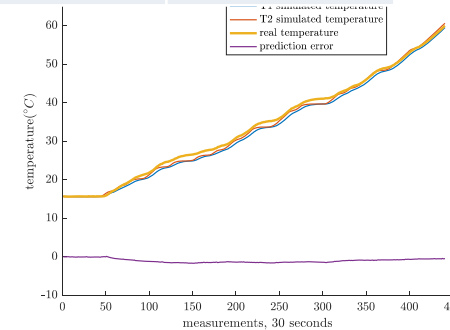
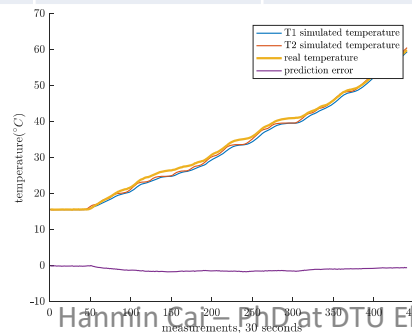

Interaction across networks

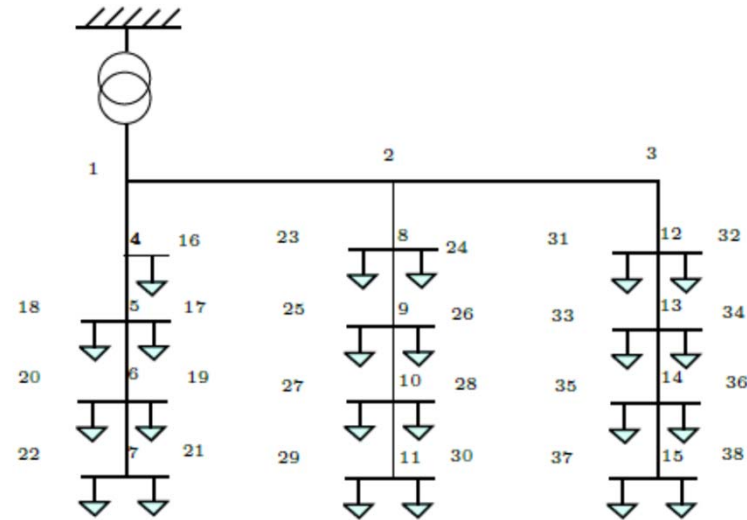
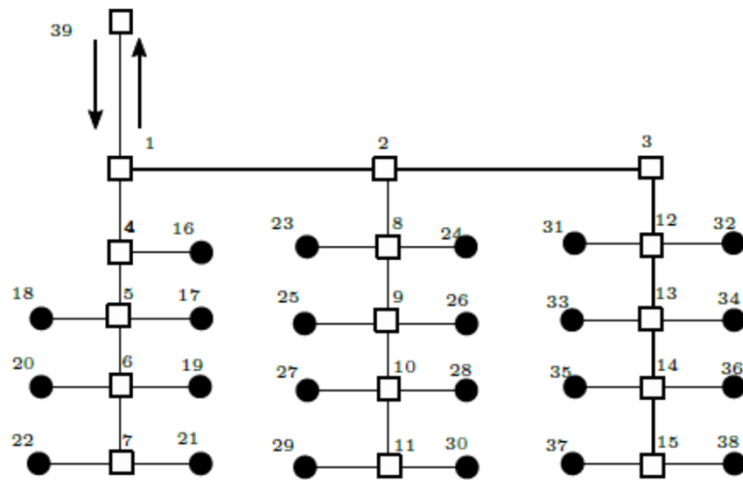

Network service



- Services
 - For district heating : peak shaving
 - For power system: balance fluctuating wind power production

- Demonstration:
 - Real time energy price
 - Explicit control signal

Example: response to real time price

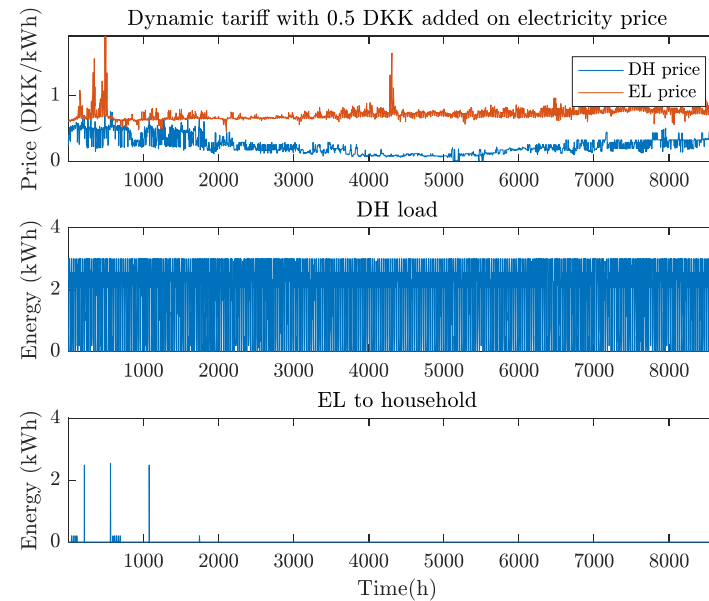
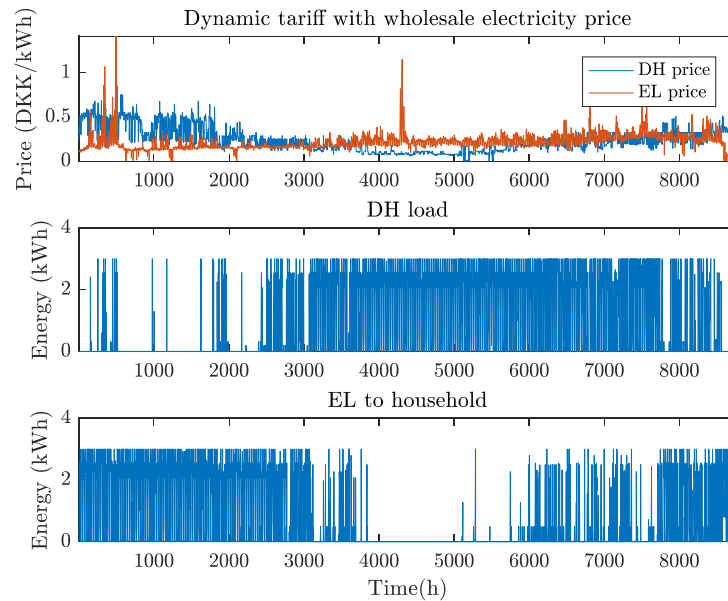

Electricity tax eliminates interactions

Potential new business



- Heat subscription
 - benefit from fluctuating electricity price
 - economic evaluation of ownership
- Flexible heat loads give
 - more flexibility to CHP operation
 - potential to reduce network loss

Case study of Nordhavn area

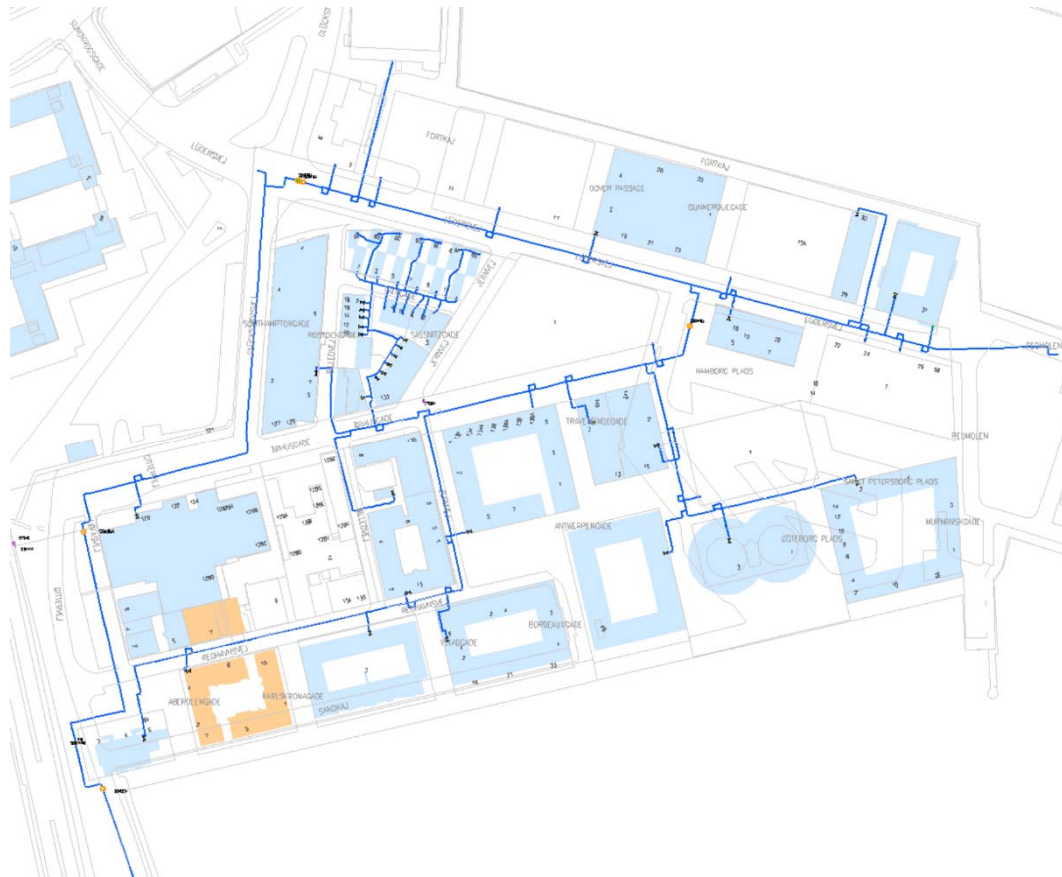

Remarks



- Heat booster as a solution to LTDH bottleneck is a source of flexibility in future energy system
- Demonstration of integrated operation in Nordhavn



Questions?